

Recording and Measurement Microphones

Rod Elliott (ESP)

Introduction

The purpose of this article and small group of projects is firstly to introduce the electret microphone into the ESP projects lineup, and secondly to allow the reader to build a microphone that although uncalibrated, can be used to great effect as a measurement mic with any loudspeaker project, or for very high quality recordings.

Traditionally, measurement microphones are calibrated, so that the exact output level for a given SPL is known, and so that the frequency response is predictable and accurate. These are fine goals, but few hobby speaker builders can afford (or can justify) the expense of a fully calibrated measuring set, or even the microphone by itself.

The measurement mic project here is not calibrated for level or response, but relies on the reasonably predictable performance of electret microphone units. These are readily available, very cheap (less than \$5.00 in any currency), and are usually surprisingly good.

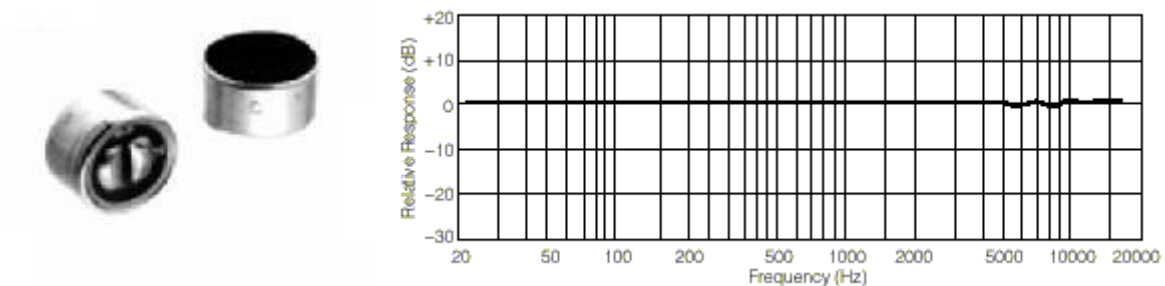

Figure 1 - Typical Electret Capsules (a) and Frequency Response (b)

Figure 1 shows what they look like, and a typical frequency response (Panasonic capsules and response are shown - but this is also typical of many others). This is extremely good performance, and is fairly close to what you can expect.

Additional microphone projects will be presented when I get the opportunity, with some hopefully interesting variations to the concept of a basic microphone as described here. Most applications will require a directional mic, and these will be discussed in the next article. Unfortunately, the casing is much more complex and critical for a directional mic than for an omnidirectional version - fortunately, measurement mics need to be omnidirectional, so that limitation is not a problem ... yet.

Powering

Traditionally, electret mics are powered from a 1.5V cell, in a very simple circuit as shown in Figure 2. Shown is the schematic for a Radio Shack "Boundary" microphone, and this is actually more complex than most - the inductor is not usually used. Like all such simple circuits, this has some very real disadvantages.

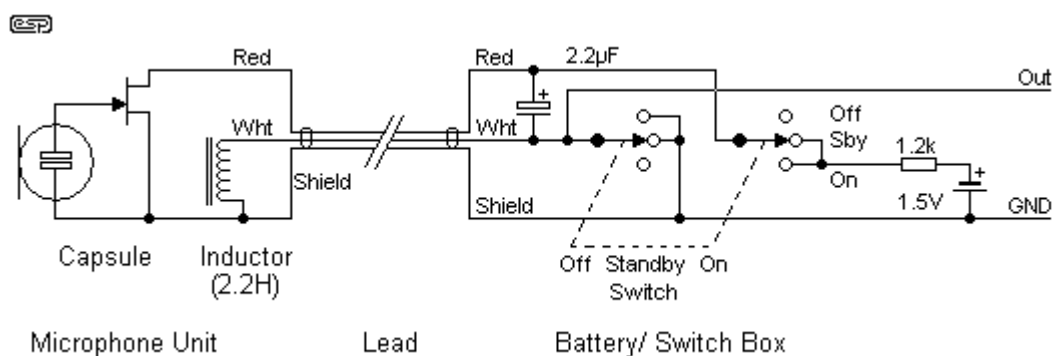

Figure 2 - Typical Electret Microphone Schematic

The disadvantages of the standard method (and commercial electret microphones in general) are ...

- 1 Output impedance is relatively high (typically about 1k to 5k)
- 2 Signal output is limited (relatively low sensitivity)
- 3 Noise is relatively high
- 4 Sound level handling ability is low (typically < 90dB SPL)
- 5 They are normally available from retail outlets very cheaply

These have caused such mics to have a poor reputation, however, with some additional work excellent results can be achieved. The first objection is easily resolved with an opamp to buffer the output, making sure that the output impedance is kept low. It is easy to achieve an impedance of 100 ohms or so, and this will drive any mixer.

The second objection is resolved by increasing the supply voltage. 1.5V is simply too low to be useful, and a supply of 9V or more is recommended. This in turn solves the next two problems as well, since with more signal from the mic the noise contribution is lower, and a higher supply voltage allows much more output voltage before distortion.

The final objection remains, and we can't change that, but we can use it to our advantage. The idea that something so cheap is capable of excellent performance is somewhat disconcerting - the expectation is that if it is very cheap, it cannot have high performance. This is actually not the case at all.

I have used a modified hyper-cardioid electret mic (which cost less than \$50 at the time) and achieved excellent results for recording voice announcements. In many cases, the quality was better than that from a professional studio, even though the recordings were done in an ordinary (but reasonably quiet) room, and having no acoustic treatment whatsoever.

The original mic was housed in a plastic case, with zero shielding (so it picked up lots of electrical noise), and used a 1.5V cell as its power source. After modification, the case was fully shielded, and it used a modified power feed directly from the mixer - not 48V phantom power, just the 15V supply from the mixer itself. Output level and signal handling ability were increased dramatically, and the results were very impressive indeed - all for \$50 or so, and a bit of modification.

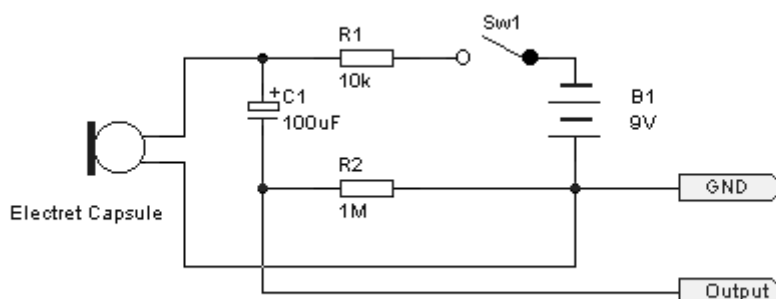

Figure 3 - Remote Powered Electret Measurement Mic

Figure 3 shows a simple remote powered microphone schematic - this can be used directly as a measurement mic with a 9V battery, and will give very good results as long as lead lengths are kept short. Generally, a circuit such as that shown should only be used with a maximum of a metre or so of low capacitance cable. If this is not enough (and it usually won't be), it is necessary to use an amplifier to reduce the output impedance. It is usually worthwhile to include some extra gain as well as shown in the schematics below.

The standard "off the shelf" electret mic may not be calibrated, but typical inserts will be acceptably flat from 20Hz to 10kHz, often with a 3dB rise at 18kHz before rolling off again. A typical response graph is shown above in Figure 1b. While it is obviously impossible to guarantee that the one you get will be the same, it is unlikely that it will be wildly different.

I have included a photo of my prototype probe, and based on initial tests, seems to be remarkably close to a Behringer measurement mic that I have performance wise, but a great deal cheaper. The output is very high with either of the amplifiers shown below - I have measured about 50mV at 70dB SPL, and it has a clean undistorted output at 100dB SPL of almost 1.6V RMS. Based on this, it is obviously not suited to measuring extreme SPLs, but as a measurement mic it is perfect.



Figure 4a - Behringer Measurement Microphone

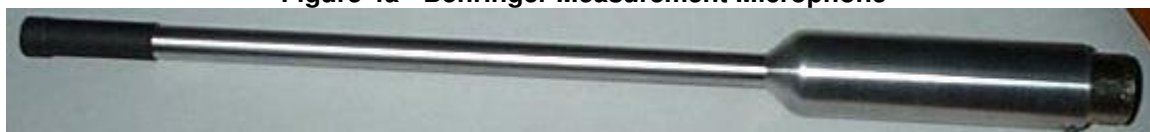

Figure 4b - My Prototype Measurement Mic Probe

The long tube ensures that there is minimal diffraction interference from the casing, and the final unit has a turned aluminium casing, and is phantom powered. Since the PCB needs to be very small, it was not possible to finish the unit until I had PCBs made - these are approximately 12.5 x 50mm (or 0.5" x 2"), and are now available. The prototype amp was built first, and works extremely well (see [Project Proper](#), below), but alas is too big to fit into the casing.



Figure 4c - Photo of Completed Preamp

Figure 4c above shows what the preamp looks like. I attached mine directly to the modified XLR connector, using PCB pins carefully bent to fit the receptacles of the XLR. The connections on the board are designed to align with the XLR connections for exactly this purpose. Despite the use of standard (as opposed to miniature) 100uF/16V caps throughout, the completed assembly does fit into the casing perfectly - there is not a lot of room for error, but it does fit. This was my intention from the outset, and the idea is to be able to use a standard 19mm (3/4") inside diameter tube to match the connector diameter.

Note: I have produced a small number of housings, and the "exploded" photos are shown below. These are available now, and include the XLR connector (machined to fit the housing), a PCB and PCB pins, copper tape, and two ferrite beads - all basic hardware. You will need to supply the microphone and the components for the PCB, as well as some insulation and a short length of heatshrink tubing (and/ or a suitable adhesive) to secure the mic element to the end of the tube.

The main housing is machined from a solid aluminium bar, and is 25mm (1") in diameter. Photos of the component parts are shown below. Pricing is available on the [Purchase PCBs](#) page, and covers the basic hardware set as shown - the remaining components should cost you less than AU\$10, to make a complete phantom powered microphone.



Mic Casing Detail



The Other Parts

In case you were wondering, the steel rule is not part of the deal :-). It is shown so that you can see the relative size. The copper strip is used to wrap around the XLR, so that the case is properly earthed via pin 1. The complete assembly details are available in the secure section, and has step by step photos. Such photos are normally needed, but with a mechanical assembly it is essential. The screws are to secure the mic tube and the XLR connector via the recessed holes visible in the upper photo. The final assembly has a nice solid feel, and is extremely easy to put together. Not shown (but included) are the ferrite beads for the mic's outputs.

Pressure Zone Microphones[®] (PZM[®])

The original Pressure Zone Mic was developed quite some time ago, and I have one of the very first ones that were available (manufactured by Wahrenbrock). Crown Audio has been making these since 1980, and Radio Shack (known as Tandy in Australia) also makes one (now called a boundary microphone) that is easily modified to be of near studio quality. Again, all it needs is a decent power supply, and a buffer or amplifier to ensure that the output impedance is kept low (and balanced) to match up with professional mixing desks. The original Radio Shack unit was a true PZM microphone, but it must be noted that the new ones are not - similar, but not the same. See Figure 2 for the schematic of the standard unit.

To make the modifications, the case does not even need to be undone. If you want to see what's inside, the latest ones have 4 screws under the rubber pad on the bottom, and this must be removed. It is attached with double sided tape (such as carpet tape or similar, which can be used to re-attach it when you are done playing). There is a small PCB inside amongst some medium density foam. The top piece can be removed, and the mic terminals are then accessible. The 2.2H iron cored choke (of rather dubious quality) is simply left disconnected, by not using the white wire in the shielded pair to the switch unit and battery holder (these will be discarded). The inner wiring from the mic unit is connected to the new preamp board using a suitable connector on the existing cable from the mic. A fixed lead is not recommended, but you don't have much choice at the mic end unless you really do want to dismantle it. The shield is the mic negative terminal (and also the case), and the red lead carries the signal.



Figure 5 - Radio Shack (Tandy) Boundary Microphone

Using only the shield and red lead (microphone connection - see Figure 2, above for internal schematic), this mic unit can be connected to the preamp shown below. It can then be phantom powered for theatre or other performance recording or sound reinforcement, and gives a very good account of itself indeed.

The Project Proper

Figure 6 shows the project preamp - a balanced mic line driver. This is suitable for use with phantom or battery power, and is easily adapted for either (as described below). This preamp has a PCB which is [available](#), and is suitable for use with any of the microphones shown in this article. Suitable for measurement or recording, it has high output, low noise, and may be powered from a 9V battery or phantom power from 30V to 48V. The load resistance/ impedance should be at least 1k, but this is actually considerably lower than most preamps, so will not cause a problem.

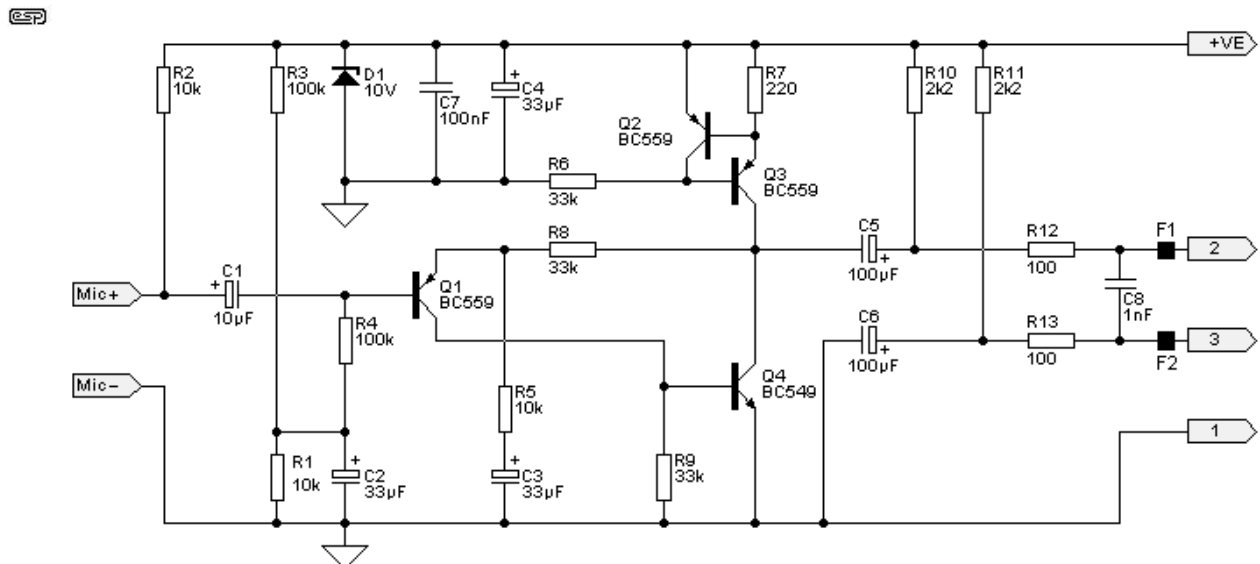

Figure 6 - Project Balanced Mic Line Driver

The preamp is very similar to the DoZ preamp - the topology is identical, but it has been modified to use a lower supply voltage. The amplifier is a single ended Class-A, current feedback circuit, which has extremely good linearity, wide bandwidth and is unconditionally stable. Ferrite beads (F1 and F2) are recommended at the outputs.

The output pins shown are the normal connections to an XLR audio connector, with Pin 1 as ground, Pin 2 is "hot", and Pin 3 is audio return ("cold"). The output actually is balanced, but is asymmetrical - this is very common, and the same basic idea is used by many premium studio microphones.

All resistors should be metal film, and electrolytic caps need to be rated at 16V. The 100uF units shown for C5 and C6 may be reduced to 33uF for recording use, but to maintain response down to 10Hz for measurement, use 100uF as shown.

To use the preamp on battery power, simply leave out R10 and R11, and connect the battery to the +VE terminal. Note that C5 and C6 *must* be reversed if you plan on using battery power, and D1 may also be omitted. Current drain is quite low (about 5mA maximum), so a 9V battery should last quite well. As noted above, PCBs are available for this version - they are tiny, and will fit easily into even small microphone housings.

This preamp can be used for a modified "boundary" mic, to make a high performance measurement mic, or to convert a cheap directional mic into something of near professional quality. It won't be the equal of a Neumann or other expensive studio microphone, but it won't set you back over \$1,000 either :-)

Opamp Version

Getting enough current from the phantom supply of a mixer is not a trivial task. If the two 6.8k feed resistors are shorted to ground, the maximum available current is only 14mA, but with no voltage at all. For a workable current of (say) 10mA, the maximum available supply voltage is 14V DC. Getting the current as low as possible is a fine goal, but all opamps need some current to operate, and the powering circuit shown in Figure 7 is a relatively simple way to achieve the desired results.

This is the receiving end of the phantom supply, and it powers the microphone and opamp line driver. This circuit can be expected to handle sound levels up to about 110dB, and possibly more - this is more than sufficient for any microphone that is not used in close proximity to loud vocals or instruments.

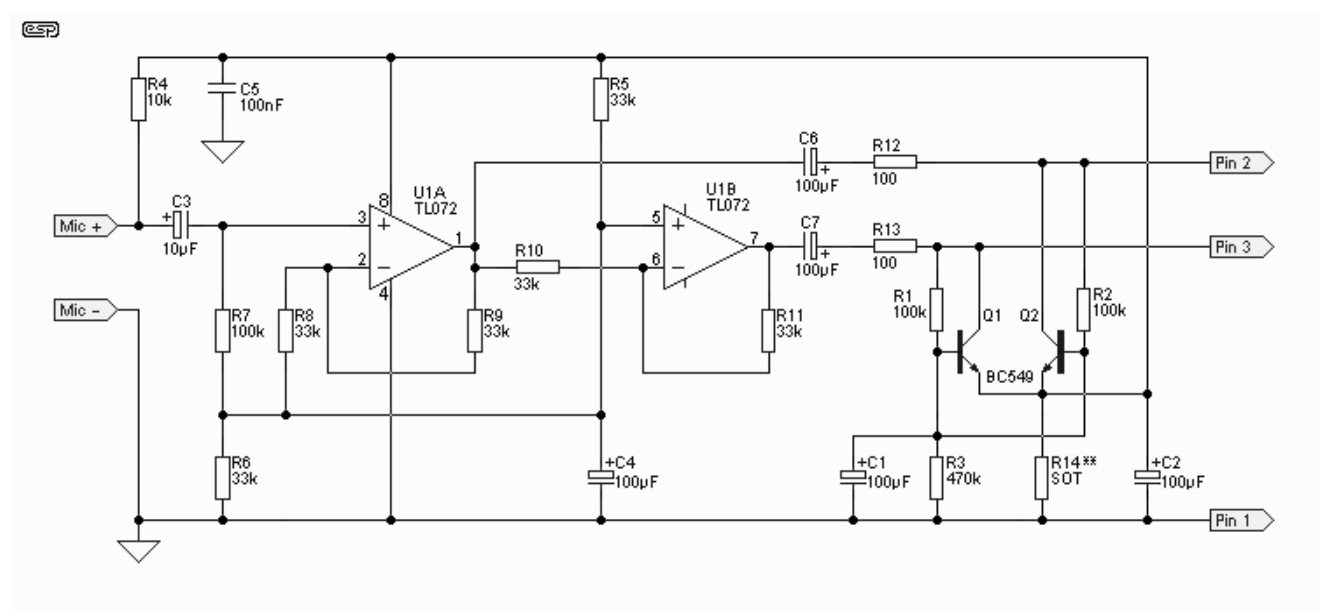

Figure 7 - Balanced Phantom Feed Opamp Mic Amplifier

A similar (but slightly more complex) method for deriving the DC from the signal lines is used by Crown in their PZM microphones, and similar circuits are also used in other (similar) mics. How does it work? It is actually quite simple. Q1 and Q2 are operated as current sinks, and the load is connected to the emitters. Because a current sink (or source) has an extremely high impedance on the collector, there is minimal loading of the signal lines. The DC appearing at the bases is filtered by C1, so the collectors only "see" the DC - the AC signal is left untouched except at extremely low frequencies (less than 1 Hz for the circuit shown above). R14 (marked **) is described as "S.O.T", or select on test. This resistor needs to be chosen so that the DC is about 10V with a normal phantom supply of 48V. A zener may be used instead, which will give a little more voltage range - depending on the opamp used.

R3 is used to ensure that there is some voltage across the transistors, and the differential must be greater than the expected peak output. As shown, the differential is about 3V, so a 6V peak to peak signal can be accommodated - this is equivalent to an output level from the microphone of almost +10dBm! This circuit has been built and tested, and works extremely well. Output level is about the same as the discrete version shown in Figure 6, but it is more complex, and a board cannot be made small enough to fit inside a slim microphone housing. No PCB will be offered for this version unless there is considerable demand.

The most common variant of my simplified DC "extraction" circuit uses a transistor as a capacitance multiplier instead of just a capacitor. This has not been found to be necessary in practice for the schematic as shown, and I have found that it works exceptionally well without the extra complications.

My prototype preamp uses a OPA2134 (a relatively high current opamp), and gets a working voltage of a little over 10V with 48V, 6.8k phantom feed. The output level is extremely high - 2V RMS can be achieved quite easily by speaking directly into the mic ... LOUDLY! In all, this is an extremely capable preamp, with excellent specifications and performance. If demand warrants it, a surface mount version of this preamp may be made available at a later stage, as this is the only way to get the size down so it could be used in a slim microphone housing.

Sound Pressure Level

It must be realised that all electret mics have one limitation we cannot readily change, and that is maximum SPL. Because they have an integral amplifier, there will always be a level where they will distort. A capsule having a 10k feed resistor and supplied from a 15V supply will output well over 1V RMS quite easily, simply by having it close enough to your mouth as you speak loudly. Even professional microphones (including dynamic types) are quite capable of 0dBm in close proximity to a floor tom or a loud singer. As a result, close vocal work, drums and brass instruments (trumpet, sax, etc) are capable of extremely high SPL, and are not really suitable candidates for electret mics. It is possible to get good performance at up to 110dB SPL quite easily, however - possibly more.

The sensitivity can be reduced, simply by reducing the value of the feed resistor. Again, there is a limit, as the internal FET amplifier can be driven into distortion regardless of what you do on the outside of the capsule. It is feasible to modify the capsule itself - but this is only possible with some models unless you are willing to make a few sacrifices (you can guarantee that you will ruin a couple in the process).

This I shall leave to the individual constructor. One possibility if using a Panasonic mic insert, is that the external track on the PCB can be cut, and this gives access to the source of the internal FET. As shown in Figure 6, this little track can be cut, and the mic is then rewired with the FET as a source follower. I do not know what the maximum SPL that a mic modified in this way will take, but it is considerably higher than an unmodified electret capsule. Expect the microphone polarity to be reversed if you do this. The standard insert produces a positive voltage for an air compression because the electret is wired to do so.

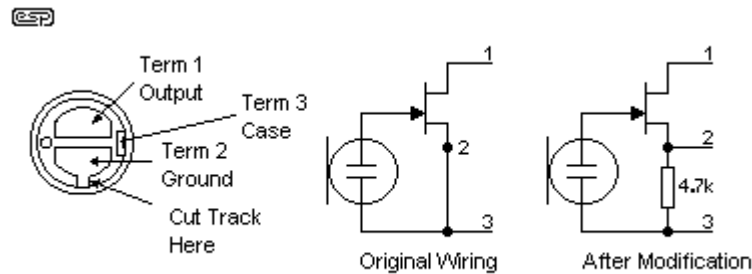

Figure 8 - Modifying a Panasonic Electret Insert

This modification was originally suggested by Siegfried Linkwitz for his cosine burst generator (see [Project 58](#)). Note that this is only known to work with the Panasonic capsule, but others may be able to be adapted in a similar manner.

The drain connection is connected to the power source with no series resistor, and the output now comes from the source (Terminal 2). There is no amplification, so expect the output level to be quite a bit lower than normal. Output impedance with a 4.7k source resistor is somewhat less than 4.7k, but it still requires an opamp (or transistor) buffer to prevent current saturation in the FET if connected to any typical mic preamp.

NOTE:

Pressure Zone Microphone[®] and PZM[®] are registered trademarks of Crown International Inc. Pressure Recording Process[™] is a trademark of E.M. Long Associates.
